

Capital Cost Reduction by the Use of Divided Wall Distillation Column

LOREDANA DRAGHICIU, RALUCA ISOPESCU*, ALEXANDRU WOINAROSCHY

University „Politehnica” of Bucharest, Department of Chemical Engineering, 1-5 Polizu Str., 011061, Bucharest, Romania

The dividing wall distillation column which is a fully thermal integrated system also brings significant capital cost reduction. The analysis of cost reduction is performed in the frame of the commercial simulator HYSYS™ and of a specialized cost evaluator software. A case study for a common hydrocarbon mixture separation in oil refiners demonstrates that the heat transfer units reduction and the use of a single column shell provide a decrease up to 23 % of the cost compared to a classical two column separation sequence. Alike the energy efficiency of the dividing wall distillation column, the capital cost reduction is more important for the case when the middle component is in a great amount in the feed.

Keywords: divided wall distillation column, capital cost evaluation, hydrocarbon separation

The separation of a ternary mixture into three pure components can be realized by a sequence of two distillation columns. A single distillation column with side draw will not provide a high purity of the middle component due to remixing phenomena. Using thermal coupling methodology, complex columns can be designed to realize this separation in a single unit. The main advantage of a thermally coupled distillation column is the energy savings up to about 40 % compared to classical simple distillation sequences [1, 2, 3]. Among thermally complex columns, the Petlyuk distillation column (figure 1 a) represents the totally coupled structure and brings the highest energy reduction. When both the prefractionator and the main column are built in a single shell, the divided wall distillation column (DWC) is generated (fig. 1 b). The thermally coupled systems have several advantages, such as lower energy consumption, lower capital costs and also reduced space requirements. The extent of economical advantages of thermally coupled distillation columns depends on the nature of the mixture to be separated, mainly on the relative volatility of the components, on feed composition and on the throughput considered [4].

The concept of fully thermal coupling distillation column was introduced in 1965 by Petlyuk [5], but practical applications and industrial use of the DWC were realized only in recent years. Several theoretical studies concerning the energy savings in a DWC are presented in literature [6-9] as well as theoretical aspects regarding the design and analysis of a DWC [10, 11]. DWC is considered a challenging solution with both energy and cost reduction for new design or retrofit practical applications [12, 4]. Despite its advantages, the industrial use of a DWC is still limited and only a few industrial applications are so far

implemented. The industrial acceptance and commercialization of DWC by companies as BASF A.G. and M.W. Kellogg is mentioned [13, 14].

The present paper presents a capital cost reduction analyses of the DWC compared to a classical two-column distillation sequence used to separate a hydrocarbon mixture into three products. A case study is presented for the separation of a common mixture in oil refineries: benzene, toluene, ethylbenzene and o-xylene aiming to obtain high purity benzene as light product, toluene as middle product and ethylbenzene and o-xylene as bottom product. The commercial simulator HYSYS™ is used to establish the optimal configuration of the DWC and to estimate the column main dimensions. Cost evaluations were performed using specialized software CAPCOST.

Short-cut design and rigorous simulation of the distillation system

The direct sequence of the simple distillation columns sequence (fig. 2) was designed by a short cut method, based on Fenske-Underwood-Gilliland method implemented in HYSYS simulator, which was further adjusted by rigorous simulation. A feed of 200 kmol/h was considered. The feed composition in mol fractions was: benzene 0.17, toluene 0.60, ethylbenzene 0.06, o-xylene 0.17. In the final separation sequence the number of theoretical trays was 20 in the first column and 24 in the second column. The feed tray locations were established by simulation aiming to obtain a minimum energy requirement in the reboilers.

The structure of the DWC was estimated by a short cut method using a thermodynamically equivalent structure with three columns [13] as presented in figure 3. The

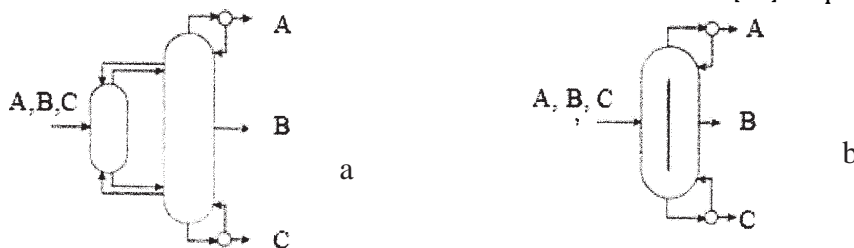

Fig.1. Petlyuk distillation column (a) and dividing wall distillation column (b)

* email: r_isopescu@chim.upb.ro

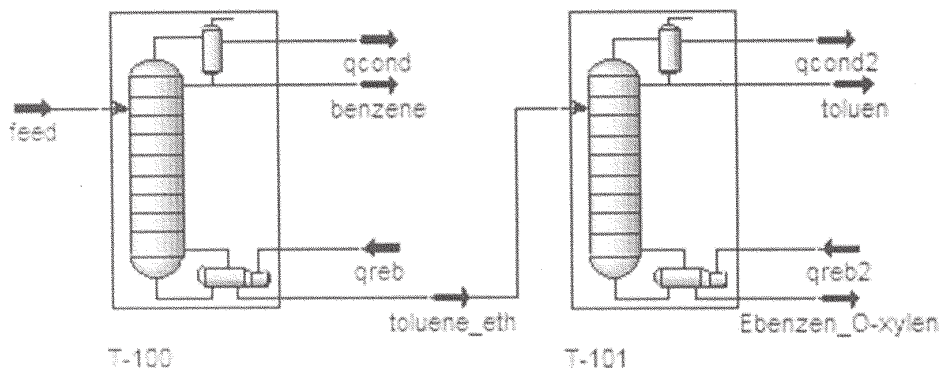

Fig. 2. Two columns separation sequence

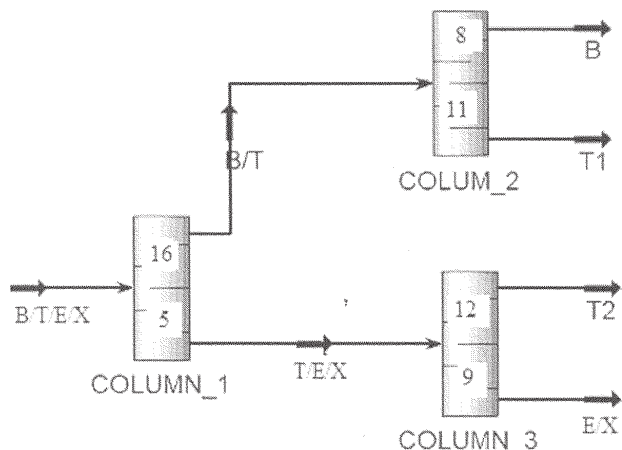

Fig. 3. Three columns model for DWC short-cut design: Benzene (B), Toluene (T), Ethylbenzene (E), o-Xylene (X)

number of theoretical trays and feed locations for this equivalent structure were estimated in the frame of HYSYS using the short-cut distillation module and are indicated in figure 3. As HYSYS™ has not a specific module for a DWC, the rigorous simulation was performed using four tray sections interlinked by liquid and vapor streams (fig. 4). This is a thermodynamic equivalent structure as well, which can be easily built from the three-column model used in short-cut design. The four columns model is more adequate for equipment sizing stage as each tray section has a well defined cross section. For rigorous simulation, the same number of trays was considered on both sides of the dividing wall, as this is solution that can be easily built and is therefore recommended when the DWC is a tray column.

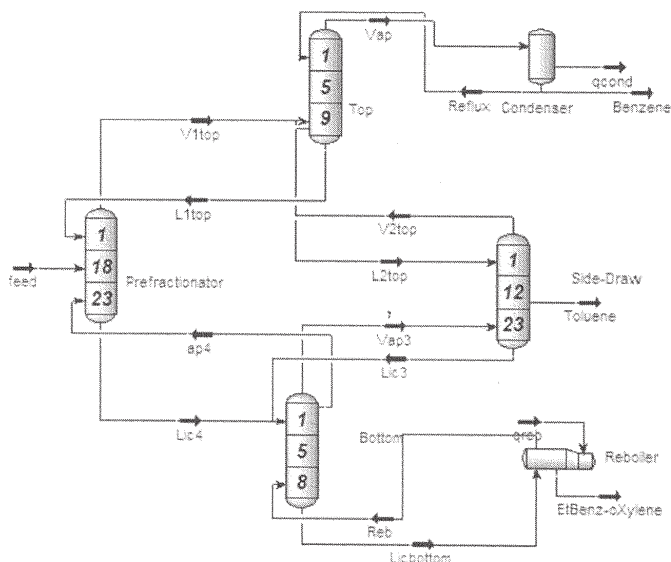

Fig. 4. DWC structure in the frame of HYSYS™ simulator

In figure 4, the „Top” section represents the trays above the dividing wall, the „Prefractionator” and „Side-Draw” stand for the left and right side of the dividing wall, while by „Bottom” is denoted the section below the dividing wall. The number of trays in each section, the feed tray, side-draw location and the position of thermal coupling streams, as identified by short-cut design, were slightly modified by repeated rigorous simulations, aiming to realize at a low reboiler duty the purity requirements (more than 0.95 mol fraction) in the three products.

Antoine model was used to calculate the thermodynamic properties of the mixture.

Main equipment sizing

In order to evaluate the capital costs, the equipment implied in the separation flowsheets were sized using the HYSYS™ options and databases. The two distillation columns in the direct sequence (fig. 2) and the tray sections in the DWC model were sized considering sieve trays with overall efficiency of 0.75. The distance between the trays was set to 0.4 m. The other data, such as the overflow, free weight area, the flooding conditions were taken according to standard simulator options. Under these conditions, for the direct separation sequence (fig. 2) the two columns diameters were 1.22 m and 1.68 m. The corresponding heights were 15.85 m and 17.07 m. As can be noticed, the second distillation column is larger in size as the internal vapor flow was also higher of about 330 kmol/h compared to 180 kmol/h in the first distillation column.

The two reboilers were considered of U tube-kettle type and the condensers as tubular heat exchangers with fixed tubular plate and bonnet round cap. The calculation of main geometric dimensions for heat transfer equipment as implemented in HYSYS™ simulator is based on an automatic selection of the utility (cooling water or steam) according to the temperatures of technological fluids. A heat balance provides the flow rate of utility and, considering the heat transfer equipment type selected, an overall heat transfer coefficient is evaluated. The main geometric dimension that is required for further cost evaluation is the heat transfer area. In the two columns sequence, the heat transfer area of the condensers were 21 m² for the first column and 28.9 m² for the second column. The heat transfer area of reboiler of the first column was 16.2 m², while the reboiler of the second column had a surface of 39.6 m².

For the DWC, the sizing step referred to each tray section according to the structure presented in figure 4. The same options concerning the tray type and distance between the trays were selected. Figure 5 presents the tray section sizing step in the frame of HYSYS simulator, while figure 6 contains the reboiler sizing results. All characteristic dimensions for the tray section in the DWC structure and associated heat transfer equipment are presented in table 1.

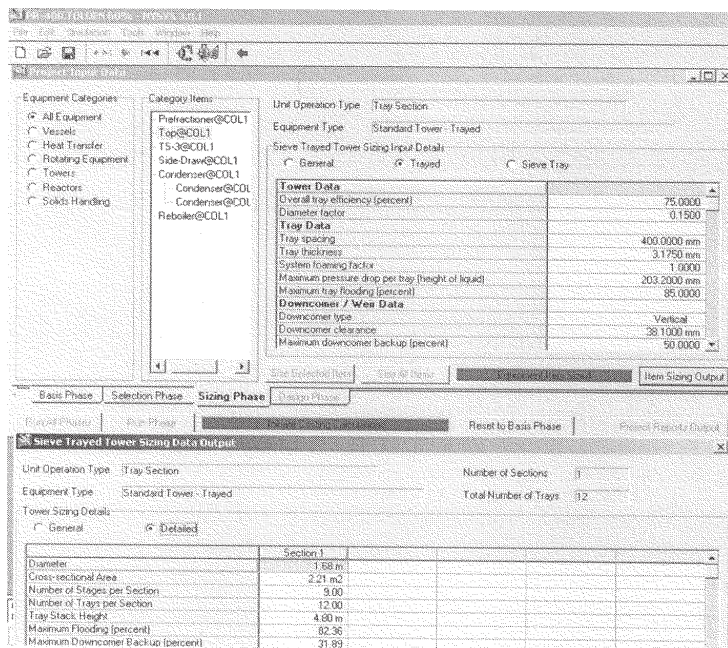

Fig.5. Sizing step results for the "Top" region in the DWC

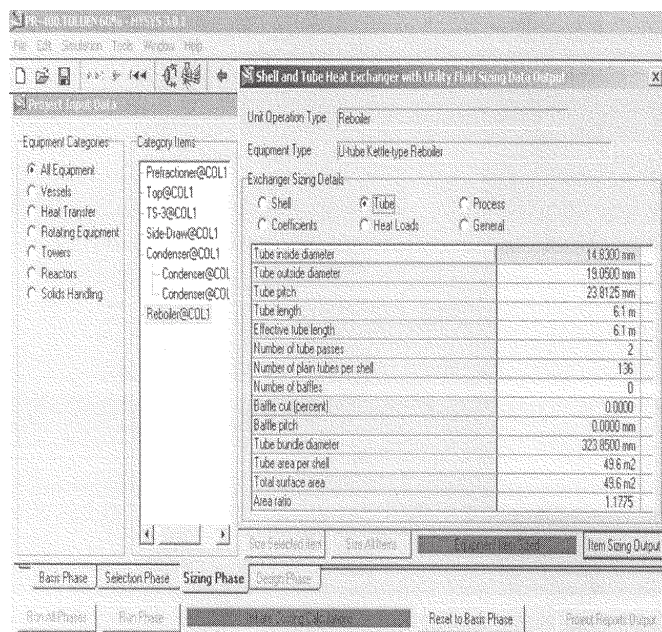

Fig.6. Results in sizing step for the DWC reboiler

Taking into account that the DWC was simulated by four interlinked tray sections that are included in a single column, the cost evaluation was performed by formulating a single column shell, with constant diameter and having the total height defined as the sum of Top height, Prefractionator height and Bottom height, which represents 21.6 m. The diameter of the DWC in the region of the dividing wall was calculated as the diameter corresponding to the sum of cross section area in the prefractionator and side-draw region. This equivalent diameter is 1.77 m. In the cost evaluation step this diameter was considered for the entire DWC.

Cost evaluation

Cost evaluation was realized in the frame of a specialize software, respectively CAPCOST. The database of this software allows the estimation of a large variety of process equipment costs if the characteristic dimensions are known.

The capital cost of the DWC was estimated using the simple distillation column option (fig. 7) and increases with

10 % to include the costs of special internal adjustments required by the existence of the dividing wall.

A single reboiler and a single condenser are associated to the DWC. Their cost evaluation is presented in figure 8.

The total capital cost of the DWC was 484 441 \$ while the cost of the two column sequence was 625 684 \$. As can be noticed a significant cost reduction of about 23% can be realized by using the DWC.

All calculation above mentioned were repeated for two other feed composition, corresponding to 0.5 and, respectively, 0.3 toluene mol fraction. The results are synthesized in table 2. As table 2 shows, the capital cost reduction increases with the concentration of intermediate component in the same sense in which increases the energy efficiency, as it was presented in a previous work [8]. The saving resides not only in the reducing of heat transfer equipment cost, but also in a smaller column cost, although it is well known that DWC is a large size equipment.

Table 1
DWC SIZING RESULTS

	Top	Prefractionator	Side-Draw	Bottom	Condenser	Reboiler
Diameter, m	1.68	1.52	0.91	1.81		
Height, m	4.80	12.4	12.4	4.4		
Heat transfer area, m ²					41.3	49.6

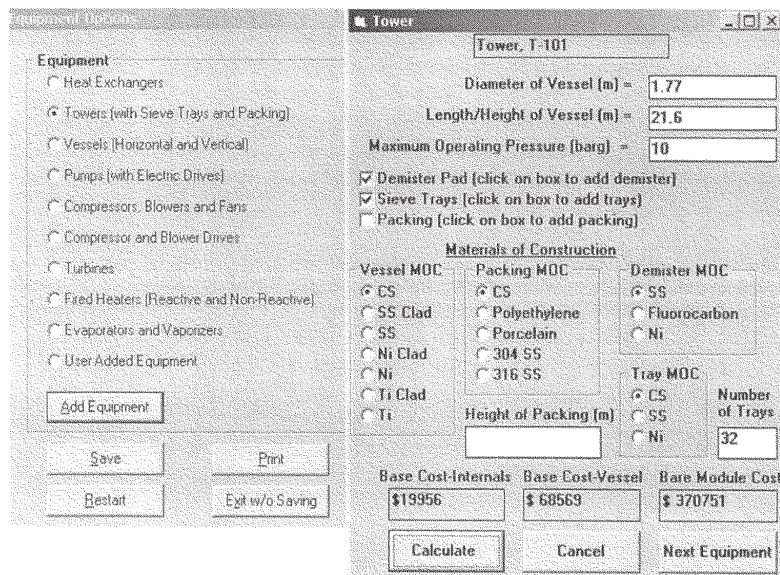
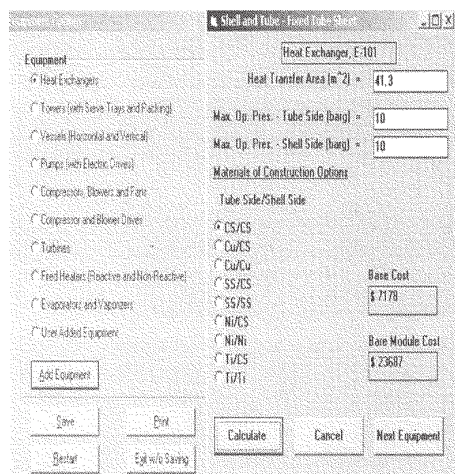
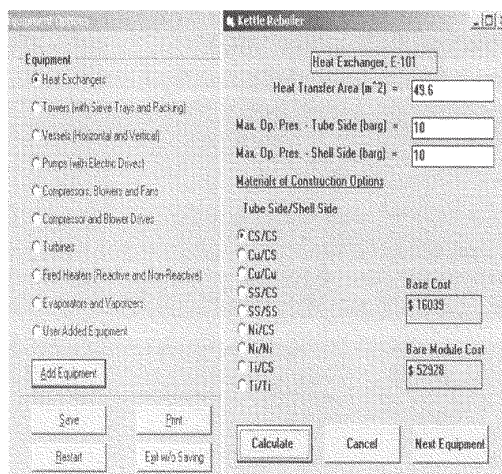

Fig.7. DWC cost evaluation



a



b

Fig.8. Condenser (a) and reboiler (b) cost evaluation

Toluene feed concentration, mol fraction	Capital cost for two columns separation sequence, \$			Capital cost for DWC \$			Cost Reduction, %
	Columns	Heat transfer equipments	Total	Column	Heat transfer equipments	Total	
0.3	477471	108941	586412	460475	71988	535463	10
0.5	496092	111643	607735	425792	74380	500190	18
0.6	512628	113056	625684	407826	76615	484441	23

Table 2
COST EVALUATION FOR DWC AND TWO COLUMNS SEPARATION SEQUENCE

Conclusions

The present work investigated some possibilities to design complex distillation columns and to evaluate the capital cost. The DWC proved to bring important economical benefits in term of capital cost reduction. A

case study demonstrated the effectiveness of interconnection between different software environments for the design engineer.

References

1. TIJANI, A, RAMZAN, N., WITT, W., Rev Chim. (Bucuresti), **58**, nr. 4, 2007, p. 392
2. HERNÁNDEZ, S., SEGOVIA-HERNÁNDEZ, J. G., RICO-RAMÍREZ V., Energy, 31, 2006, p. 2176
3. FERES, O. A., CAEDENAS, C., HERNANDEZ, S., RICO-HERNANDEZ, V., Ind Eng Chem Res, 42, 2003, p. 5940
4. SCHULTZ, M. A., STEWART, D. G., HARRIS, J. M., ROSENBLUM, S.P., SHAKUR, M. S., O'BRIAN D. E., Chem Eng Prog, May 2002, p. 64.
5. PETYLUK, F.B., PLATONOV, V.M., SLAVINSKII, D.M., Int Chem Eng, 5, 1965, p. 555
6. RÉV, E., EMTIR, M., SZITKAI, Z., MIZSEY, P., FONYO, Z., Comp. Chem. Eng., 25, 2001, p.119
7. TAMAYO-GALVÁN, V.E., SEGOVIA-HERNÁNDEZ, J.G., HERNÁNDEZ, S., CABRERA-RUIZ, J., ALCANTERA-AVILA, J.R., Comp. Chem. Eng., 32, 2008, p. 3057
8. ISOPESCU, R., WOINAROSCHY, A., DRAGHICIU, L., Rev. Chim.(Bucuresti), **59**, nr. 7, 2008, p. 812
9. ISOPESCU, R., PLESU, V., BUMBAC, G., POPESCU, C. D., IVĂNESCU, I., "Dividing wall column – a challenging solution for energy saving in light hydrocarbon separation in oil refineries", Romanian International Conference on Chemistry and Chemical Engineering, RICCE XIV, 21-24 September 2005, Bucharest, Romania.
10. EMTIR, M, RÉV, E., FONYO, Z., Applied Thermal Eng, 21, 2001, p. 1299.
11. PREMKUMAR, R., RANGAIAH, G. P., Chem. Eng. Res. Des., 87, 2008, p. 47
12. AMMINUDIN, K.A., SMITH, R., Trans IChemE Part A, Chem. Eng. Res. Des. 79, 2001, p. 716
13. AMMINUDIN K, A., SMITH, R., THONG D,Y.C., TOWLER, G. P., IChemE, Part A. Chem. Eng. Res. Des., 79, 2001, p. 701
14. ADRIAN, T., SHOENMAKERS, H., BOLL, M., Chem. Eng. Process., 43, 2004, p. 347

Manuscript received: 310.03.2009